

# ECHO-PIEZO TRANSDUCER

B93 SERIES

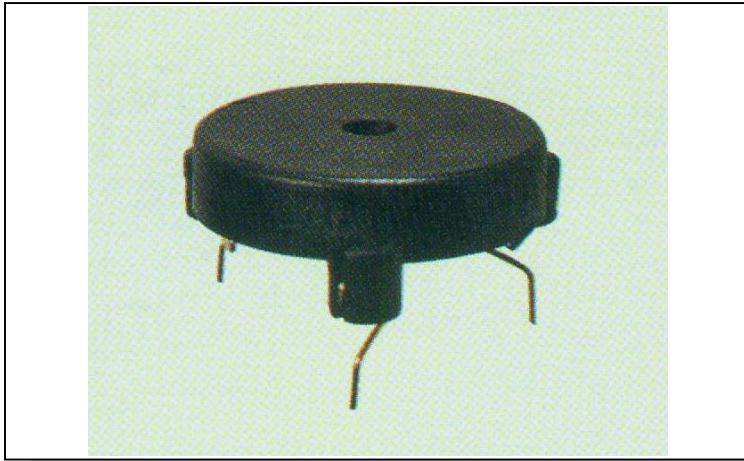

## FEATURES:

- Feed-back type
- Emit a clear penetrating sound
- Low current consumption
- Extremely durable & long life
- Operating temperature  $-20^{\circ}\text{C}$ ~ $+70^{\circ}\text{C}$
- Storage temperature  $-30^{\circ}\text{C}$ ~ $+70^{\circ}\text{C}$

## TEST CIRCUIT

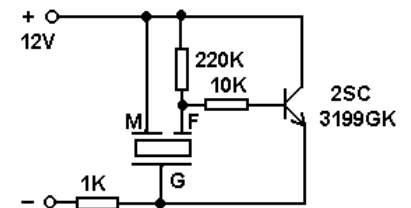

## DIMENSIONS: (unit: mm)

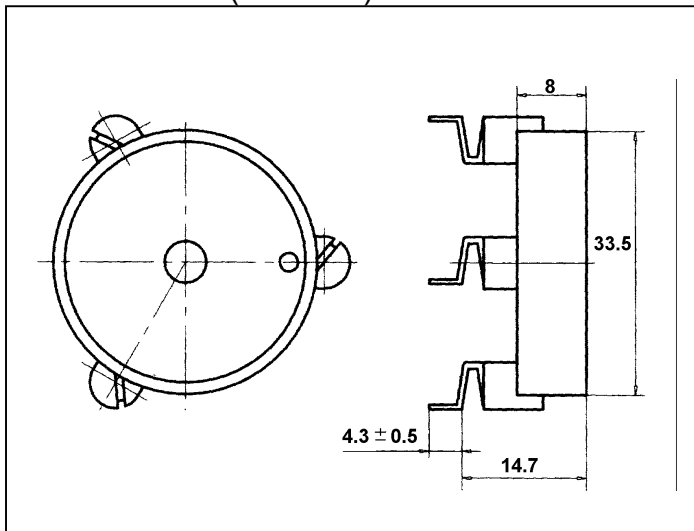

## FREQUENCY RESPONSE:

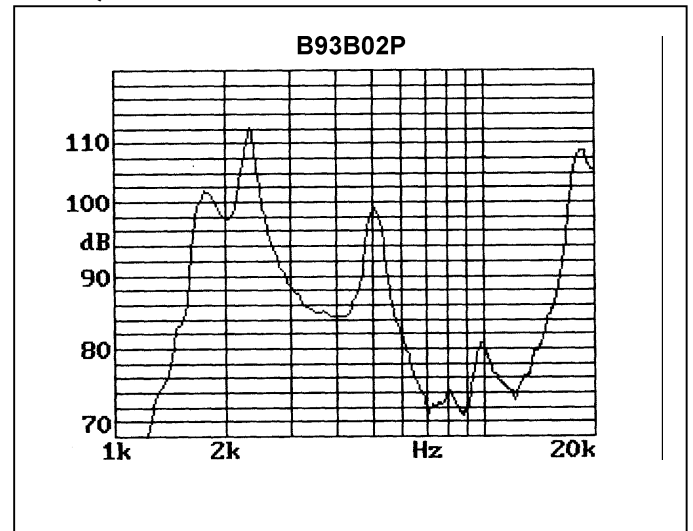

## SPECIFICATIONS:

Model Number	B93B02P
Sound Pressure Level	88dBA Min. at 10cm
Static Capacitance	18,000pF $\pm$ 30% at 120Hz
Frequency Range	1000-5000Hz
Input Voltage	12VDC
Max. Input Voltage	20VDC
Current Consumption	8mA Max.
Operating Temperature	$-20^{\circ}\text{C}$ ~ $+70^{\circ}\text{C}$
Storage Temperature	$-30^{\circ}\text{C}$ ~ $+80^{\circ}\text{C}$
Weight	7g